

LAMINAR TORCH MODE OF AERODYNAMIC CHOKING OF A FLAT CHANNEL

I. V. Voloshin, B. I. Bondarenko,
Ya. A. Voloshina, and A. V. Kolesnichenko

UDC 621.1

A free-convection mechanism of movement of the atmosphere flowing from a sterile chamber through a flat horizontal channel, when the ambient atmosphere is drawn in, has been described. Calculated depths of ambient atmosphere penetration into the channel and dependences of the Reynolds number of the chamber atmosphere on the Grashof number, obtained by solving self-similar boundary layer equations written in the Boussinesq approximation, are given.

In calculating the gas regimes of furnaces, buildings, storehouses, etc. one encounters the problem of maintaining atmosphere sterility in a technological chamber connected to the outer atmosphere through a horizontal slot channel. Here a conditioned atmosphere is supplied to the technological chamber, and the atmosphere flows out through outlet aperture of the channel. Maintenance of the chamber atmosphere sterility, which enables performance of the technological process in the chamber, allows for aerodynamic choking of the channel by the chamber atmosphere flow due to convective and diffusive propagation of air through the channel directly into the chamber. The literature describes rather thoroughly the forced choking modes for horizontal slot channels [1, 2]. The present work is devoted to investigating the poorly studied mode of free-convection choking of a channel.

We consider a physical model of atmosphere flow in a channel (Fig. 1). Let the Grashof number be quite large ($Gr \gg 1$). Then the mixing zone for the chamber atmosphere and the air forms a thin boundary layer with free borders, i.e., a free torch [3], that is located in general inside the channel and whose width is substantially less than the height of the channel H . The torch, reaching the upper wall of the channel, turns to the outlet aperture and forms an arched near-wall torch directed toward the outer aperture of the channel. Here, the free torch ejects air that is drawn into it through the outlet aperture of the channel and moves thereby oppositely to the near-wall torch. The torch is maintained by the flow of the chamber atmosphere. The intensity of the vertical free-convection flow depends on the intensity of the forced injection of the atmosphere into the free torch and, in turn, determines the intensity of the ejection of air by the torch. The position of the torch in the channel is determined by the condition of equality of the momenta of the flows of the atmosphere and the air, i.e., the torch is considered as a gas gate. If the atmosphere flow momentum is greater than that of the air flow, then the torch is blown out of the channel. Otherwise, the torch is drawn deeper into the channel. When the torch is located directly at the outlet aperture, air does not enter into the channel, and the chamber is completely choked aerodynamically. If the torch is located in the channel at a certain distance from the outlet, propagation of air into the chamber is prevented but air penetrates into the channel. This mode also maintains the sterility of the chamber atmosphere and is called a partial choking mode. In comparison with the complete aerodynamic choking mode the latter is more economical in terms of consumption of the atmosphere.

Let the chamber atmosphere and the ambient atmosphere (air) have the same chemical composition and differ negligibly in temperature. The temperatures of the chamber atmosphere and the air are denoted by t_0 and t_∞ , respectively. Here $t_0 > t_\infty$. P_0 and P_∞ are the pressure in the torch and that of the ambient air, respectively. The pressure P_0 is determined below. Since the free-convection layer is quite thin and changes in density are negligible, then within the framework of boundary layer theory this problem may be described by self-similar equations written in the Boussinesq approximation [3]:

Gas Institute, Academy of Sciences of Ukraine, Kiev. Translated from *Inzhenerno-Fizicheskii Zhurnal*, Vol. 66, No. 5, pp. 556-560, May, 1994. Original article submitted September 9, 1992.

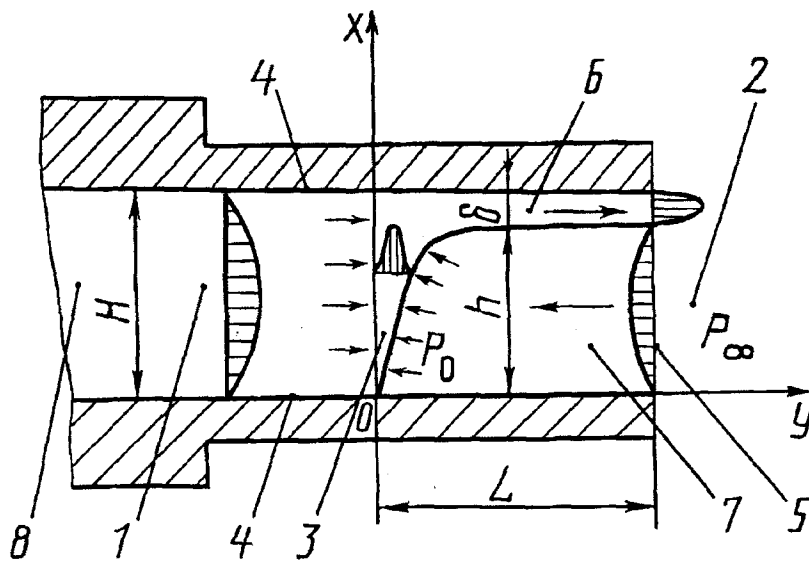

Fig. 1. Diagram of atmosphere flow in a channel: 1, 2) the chamber atmosphere and the ambient atmosphere (air), respectively; 3) the free torch; 4) the lock chamber walls; 5) the outlet aperture of the channel; 6) the arched near-wall torch; 7) the bottom air flow; 8) the sterile chamber.

$$f''' + 3ff'' - 2f'^2 + \Phi = 0, \quad (1)$$

$$\Phi'' + 3Pr f\Phi' = 0, \quad (2)$$

and here

$$\psi(x, \eta) = \nu^4 \text{Gr}_x^{0.75} f(\eta), \quad (3)$$

$$\Phi(\eta) = (t - t_\infty)/(t_0 - t_\infty), \quad (4)$$

$$\eta(x, y) = 4^{-0.25} \text{Gr}_x^{0.25} y/x, \quad (5)$$

where $\text{Gr}_x = g\beta(t_0 - t_\infty)x^3/\nu^2$.

We consider separately the formulation of the boundary conditions for problem (1), (2). In the present investigation we use the following boundary conditions:

$$f(0) = f_0, \quad f'(0) = f'(\infty) = 0, \quad (6)$$

$$f' + 3Pr f(0)(1 - \Phi(0)) = \Phi(\infty) = 0. \quad (7)$$

It should be noted that problem (1),(2) with boundary conditions (6),(7) is to be considered as a certain approximation of the free torch problem of interest because at the left boundary of the torch ($\eta = 0$) the value of the tangential stresses is found to differ from zero, which is not characteristic for a free torch (for the torch $f''(0) = 0$). However, preliminary studies of a free torch with symmetric flow of the chamber atmosphere and the air ($f(0) = f(\infty)$) under the boundary conditions

$$f''(0) = 0, \quad f(0) = f'(\infty) = 0, \quad 1/2 - \Phi(0) = \Phi(\infty) = 0$$

and the solution obtained under boundary conditions (6), (7) and for $f(0) = f(\infty)$ give practically the same dependence of $f(\infty)$ on the Prandtl number:

$$f(\infty) = 0.58 \text{Pr}^{-1/3}. \quad (8)$$

This circumstance along with the fact that with increase in the injection parameter f_0 the value of $f''(0)$ is reduced, suggests the correctness of the adopted formulation of the problem for finding the dependence of $f(\infty)$ on the injection parameter f_0 .

In solving the system of equations (1), (2) Eq. (1) was replaced by the following system of two equations:

$$f' = f_1 \quad \text{at} \quad f(0) = f_0, \quad (9)$$

$$f_1'' + 3ff_1' - 2f_1^2 + \Phi = 0 \quad \text{at} \quad f_1'(0) = f_1(\infty) = 0. \quad (10)$$

Equation (9) was solved by the Euler method, and Eqs. (2) and (10) by the run-through method [4]. The maximum value of η in the calculations was 20. A typical number of divisions of the calculation region was 400.

We determine the injection parameter f_0 according to formula (3) as follows:

$$f_0 = \psi_0 / (\nu^4 \text{Gr}_h^{0.25}), \quad (11)$$

where the subscript h indicates that the Grashof number is calculated from the torch length h (Fig. 1), $\psi_0 = V/B$, V is the atmosphere flow rate, m^3/sec , and B is the channel width, m .

The calculated values of the drawing-in parameter for the air $f(\infty)$ as a function of the chamber atmosphere injection parameter f_0 at $\text{Pr} \approx 1$ are described satisfactorily by the expression

$$f(\infty) = 0.167 - 0.546 |f_0|^3 + 1.214 f_0^2 - 1.665 |f_0| + 1.345 |f_0|^{0.5}. \quad (12)$$

We describe the physical picture of the flow in terms of the injection and drawing-in parameters. When $f(\infty) > f_0$ the atmosphere is blown into the channel, and vice versa when $f(\infty) < f_0$ it is blown out of the channel, since in the former case the momentum of the air is greater than that of the atmosphere, and in the latter it is lower. In the case where the momentum of the air is greater than that of the atmosphere the excess momentum of the air is spent on overcoming hydrodynamic resistance of the channel to the motion of the air. The position of the torch is stabilized under the condition

$$f(\infty) = f_0, \quad (13)$$

i.e., when the momenta of the chamber atmosphere and air flows become equal.

For further calculations the torch length h or the maximum thickness of the boundary layer δ has to be determined. From Eq. (5) we obtain an expression for the physical thickness of the boundary layer δ :

$$\delta = \eta(h, \delta) \cdot 4^{0.25} \text{Gr}_h^{-0.25} h. \quad (14)$$

Here the quantity $\eta(h, \delta)$ represents the thickness of the boundary layer when $f'(\eta(h, \delta)) = 0.01 f'_{\max}(\eta)$ [3].

The second equation required for finding the thickness of the boundary layer is

$$\delta = H - h. \quad (15)$$

The results of solving the system of equation (14), (15) for the dimensionless length of the torch h/H taking into account that

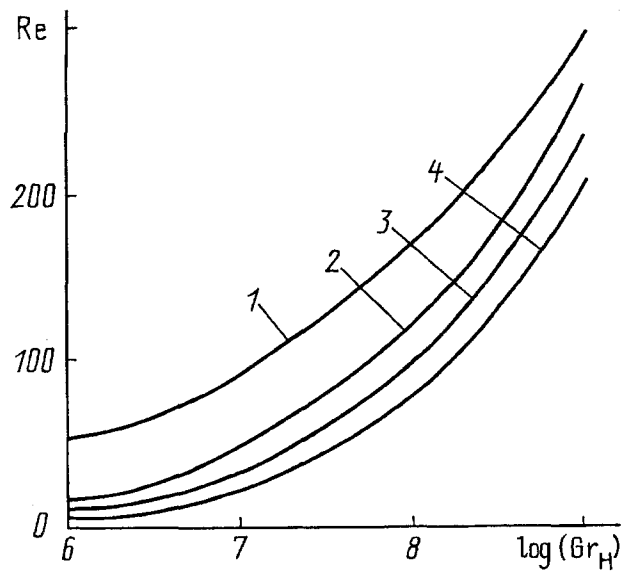

Fig. 2. Dependence of the Reynolds number of the chamber atmosphere on the Grashof number at $Pr = 1$ and for various values of depth of penetration of the air into the channel: 1) $L/H = 0$; 2) 1; 3) 2; 4) 3.

$$Gr_h = Gr_H (h/H)^3, \quad (16)$$

show that within the range $-0.8 < f_0 < -0.4$ the dimensionless torch length h/H depends virtually just on the value of the Grashof number Gr_H and at $Pr = 1$ is described satisfactorily by the expression

$$h/H = -0.169 + 0.063841 \ln(Gr_H). \quad (17)$$

Let the free torch generate a rarefaction, which we determine from the Bernoulli law, at its right boundary ($\eta = \infty$):

$$\Delta P = P_\infty - P_0 = \rho \bar{v}^2(h, \infty)/2, \quad (18)$$

where $\bar{v}(h, \infty) = \psi(h, \infty)/h$. Additionally, neglecting the inlet resistance to the air flow and assuming that the near-wall torch affects the air flow in the same manner as the wall, let us write hydrodynamic losses of the air flow in a channel with effective height h [5]:

$$\Delta P_{\text{loss}} = 32\rho\mu L\bar{v}_0/h^2, \quad (19)$$

where $\bar{v}_0 = \psi_0/h$ is the air flow velocity in the channel at the average flow rate written down taking into account condition (13), m/sec.

Taking into account formulas (18), (19), (16), (3), we obtain an expression for determining the depth of penetration of the air into the channel from the dependence $\Delta P = \Delta P_{\text{loss}}$:

$$L/H = (2^{0.5}/32) (h/H)^{0.75} Gr_H^{0.25} (f^2(\infty) - f_0^2)/|f_0|. \quad (20)$$

It is noteworthy that the aforementioned assumptions used in the derivation of formula (20) result in overstated depths of penetration of the air into the channel because the inlet hydraulic resistances and the influence of the near-wall torch on the air flow have been not taken into account.

Using formula (20) and taking into account dependences (12), (17), we have plotted graphical dependences of Reynolds number of the chamber atmosphere on the depth of penetration of the air into the channel L/H and

the Grashof numbers at $Pr = 1$, which are presented in Fig. 2. In this case, taking into account formula (3), the Reynolds number is determined as follows:

$$Re = 4^{0.75} Gr_H^{0.25} f_0 (h/H)^{0.75}, \quad (21)$$

where $Re = \psi_0/\nu$, $Gr_H = g\beta(t_0 - t_\infty)H^3/\nu^2$.

Figure 2 also shows the Reynolds number as a function of the Grashof number at $L = 0$ (the torch length h is equal to the channel height H), i.e., of the Reynolds number corresponding to the mode of complete aerodynamic choking of the aperture (Fig. 2, curve 1). The figure suggests that in accordance with the allowable depth of penetration of the air into the channel, the value of the atmosphere flow rate in a mode of incomplete aerodynamic choking is lower than that in the mode of complete aerodynamic choking. For instance, when the allowable penetration depth $L/H = 1$ or $L/H = 2$ at $Gr_H = 10^7$, the flow rate of the atmosphere expelled from the chamber may be twofold and threefold lower, respectively, than that in the case of complete choking (Fig. 2, curves 2 and 3).

It is pertinent to note that the injection parameter f_0 is suitable for classifying modes of choking of channels:

$f_0 \geq (\mu/3)Gr_H^{0.25}$: the mode of forced flow of the atmosphere into an air-filled space; at this value of the injection parameter formula (11) turns into the formula obtained in [2];

$0.58Pr^{-1/3} \leq f_0 \leq (\mu/3)Gr_H^{0.25}$: the mode of mixed convection of an ascending atmosphere stream in a gravitational field;

$f_0 \leq 0.58Pr^{-1/3}$: the mode of free convection in a torch formed at the boundary between the atmosphere and the air; in this case the critical value of the parameter $f_0 = 0.58Pr^{-1/3}$ determines the minimum flow rate of the chamber atmosphere for the mode of complete aerodynamic choking of the channel.

It should be noted that the laminar mode for torches exists at Grashof numbers lower than 10^9 [3]. Additionally, the limits imposed by the condition $Gr_H \gg 1$ on the results obtained should be taken into account. Based on literature data [6] on atmosphere flows in chambers with open apertures the following estimate of the lower limit of Grashof numbers at which the obtained results are valid can be given: $Gr_H > 10^6$.

Thus, in the present paper the laminar mode of choking of a flat horizontal channel by a free torch has been considered. A classification of channel choking modes by the values of the parameter f_0 has been given. The data obtained are useful for development of atmosphere flow rate control systems and the tuning of gas regimes of furnaces, buildings, storehouses, etc.

NOTATION

a , the thermal diffusivity, m^2/sec ; B , the channel width, m ; $f(\eta)$, the dimensionless stream function, which depends on η ; g , the free fall acceleration, m/sec^2 ; f_0 , the injection parameter; $f(\infty)$, the parameter of drawing air into the torch; $Gr_x = g\beta(\tau_0 - \tau_\infty)\xi^3/\nu^2$, the current Grashof number; Gr_h and Gr_H , the Grashof numbers calculated from the torch length h and the channel length H , respectively; h , the torch length, m ; H , the channel height, m ; L , the depth of penetration of air into the channel, m ; P_0 and P_∞ , the pressure at the boundary of the free torch with the air and the pressure of the ambient atmosphere outside the channel, respectively, Pa ; $\Delta P = P_\infty - P_0$, the rarefaction generated by the torch, Pa ; ΔP_{loss} , the pressure losses on the friction of air against the channel walls and on the near-wall torch, Pa ; $Pr = \nu/a$, the Prandtl number; $Re = \psi_0/\nu$, the Reynolds number for the chamber atmosphere; t_0 and t_∞ , the temperatures of the atmosphere and the air, respectively, $^\circ C$; $\bar{v}(h, \infty) = \psi(h, \infty)/h$, the velocity of the air at the boundary between the torch and the air at the average flow rate, m/sec ; $\bar{v}_0 = \psi_0/h$, the atmosphere flow velocity in the channel at the average flow rate, m/sec ; V , the flow rate of the atmosphere, m^3/sec ; x and y , the longitudinal and lateral coordinates, respectively, m ; β , the thermal coefficient of volume expansion, K^{-1} ; δ , the boundary layer thickness on the length of the torch equal to h , m ; $\eta(x, \eta)$, the self-similar variable, the dimensionless thickness of the boundary layer; $\eta(h, \delta)$, the dimensionless thickness of the boundary layer on the length of the torch equal to h under the condition that $f'(h, \delta) = 0.01f'_{max}(\eta)$; μ , the flow rate coefficient; ν , the coefficient of kinematic viscosity, m^2/sec ; ρ , the density, kg/m^3 ; $\Phi(\eta) = (t - t_\infty)/(t_0 - t_\infty)$, the dimensionless

excess temperature; $\psi(x, y)$, the stream function, m^2/sec ; $\psi_0 = V/B$, the stream function of the chamber atmosphere expelled from the channel, m^2/sec .

REFERENCES

1. V. E. Grum-Grzhimailo, Flame Furnaces [in Russian], Moscow-Leningrad (1932).
2. B. M. Estrin, Production and Use of Controlled Atmospheres [in Russian], Moscow (1973).
3. B. Gebhart, Y. Dzhauriya, R. Mahazhdan, et al., Weak-Convection Flows, Heat and Mass Exchange [Russian translation], Moscow, Vol. 1 (1991).
4. D. Anderson, G. Tanneheal, and R. Pletcher, Computational Hydromechanics and Heat Exchange [Russian translation], Moscow, Vol. 1 (1990).
5. E. V. Ametistov, V. A. Grigor'ev, B. T. Emtsev, et al., Heat and Mass Exchange. Heat-Engineering Experiment: Reference Book [in Russian], Moscow (1982).
6. Y. L. Chan and C. L. Tien, Int. J. Heat Mass Transfer, **28**, No. 3, 603-612 (1985).